

**TOUCHSCREEN-CONTROL**

The ATM touchscreen surface allows intuitive operation even with gloves. Up to 200 programs with all parameters can be stored and protected with password (incl. labelling field).

**POLISHING AND ETCHING UNIT**

The chemical resistant coated stainless steel housing has a large polishing table and can also be used separated from the control unit, e.g. in a lab-fume cabinet.

**Kristall 680**

The KRISTALL 680 is a fully automatic electrolytic polisher and etcher with intuitive touch-screen operation. Polishing and etching unit and control unit are separated, also the Kristall 680 can be used in the lab fume cabinet. A scan function displays the current voltage curve of a material and provides polishing results

quickly without structural changes. Handling of the polishing and etching unit was facilitated significantly by the interchangeable 1 Ltr. electrolytic tanks. Different electrolytes can be changed and easily stored with lid.

The unit is cleaned with water by a washing program.

**BASIC MODULE****KRISTALL 680 CONTROL UNIT**

Order No.: M6202000

- » intuitive operation via ATM Touchscreen surface, even with gloves
- » up to 200 programs with all parameters storable, protected per password (incl. free labelling field)
- » current & voltage diagram in real time
- » scan function for displaying a current-voltage characteristic graph
- » USB interface for creating program backup
- » media preparation for connecting a polishing & etching unit and an external etching unit (optional: connection for 2nd polishing & etching unit)
- » variable output voltage and process duration
- » automatic cooling control for mains water or recooling (current supply via Kristall 680)
- » Aluminium housing, powder-coated
- » e-lab ready



## EQUIPMENT

## POWER SUPPLY

Equipment 1

**230 V/50 Hz (1Ph/N/PE)**

Order No.: A6202000

Equipment 2

**110 V/60 Hz (1Ph/N/PE)**

Order No.: A6202001

## POLISHING &amp; ETCHING UNITS

Equipment 1

**Polishing & etching unit**

Order No.: A6202003

- » large polishing table incl. set of masks (5 pcs.)
- » touch-free pump drive (magnetic clutch)
- » stainless steel start button with integrated LED status display
- » exchangeable 1 ltr. electrolyte tank made from chemical-resistant plastic (incl. lid)
- » max. standard sample height 50mm (higher samples with ext. anode via magnetic or croc. clips)
- » polishing & etching unit can be operated separately from control unit e.g. in lab fume cabine
- » housing made from rust-free stainless steel (chemical-resistant coating) with drip tray
- » incl. connection set (electricity/water)

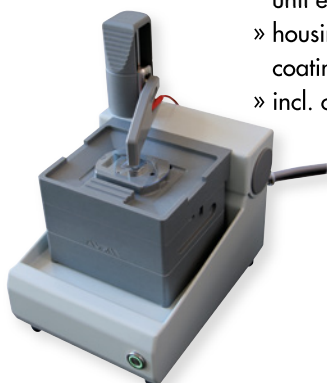
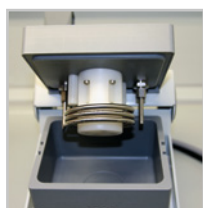

Equipment 2

**External etching unit**

Order No.: A6202004

- » etching beaker made from stainless steel
- » volume 1200 ml



Automatic drive	0–60 V
ØxH approx.	120 x 120 mm
Weight approx.	0.5 kg

## OPTION

**SECOND POLISHING & ETCHING UNIT KRISTALL 680**

- » extension for connection of second etching/polishing unit

Order No.: A6202005

## ACCESSORIES

**SET OF MASKS (5 PCS.)**

Order No.: Z6202001

- » 0.5/1.5/2.5/5 cm<sup>2</sup>/blind mask



## ACCESSORIES

**ELECTROLYTE VESSEL**

Order No.: Z6202002

- » volume 1 Ltr.
- » incl. cover
- » made from chemical-resistant plastic



## SPECIFICATIONS

## CONTROL UNIT

Connected load	2 kVA	
Power supply	1	220-240 V / 50/60 Hz (1Ph/N/PE)
	2	110-120 V / 50/60 Hz (1Ph/N/PE)

Current	0-14 A
Working voltage	0-90 V $\pm$ 0.1V regulated

WxHxD approx.	330 x 220 x 400 mm
Weight approx.	7 kg

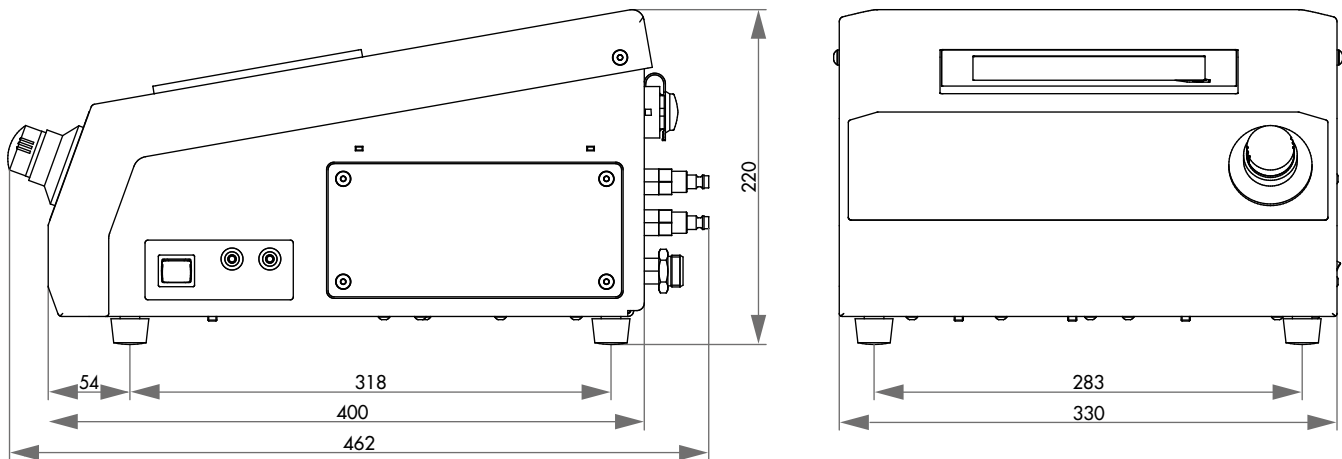

## SPECIFICATIONS

## POLISHING &amp; ETCHING UNIT

Polishing duration	1 sec.- 25 min.
Etching duration	1 sec.- 5 min.
Automatic drive	0-90 V
Polishing desk appr.	16 x 15 cm
WxHxD approx.	216 x 320 x 280 cm
Weight approx.	4 kg

